

0010 02840	1.00 EA	HLDR,PQAS3/8",PARTIAL
0020 02041-43	1.00 EA	HOSE,AIR,TYPE 1 - W/O CPLR
0025 02120-09	1.00 EA	COUPLER 1/8 NPT (TYPE1)
0030 02591	1.00 EA	BRG,BALL 5.2MM,SEALED 3/8 HLDR
0040 02043-09	1.00 EA	PIN,BRG 3/8" & 10MM HLDRS
0050 02731	1.00 EA	KNF,SCORE 3.0X.74X.204-45° 52

REVISIONS			
REV.	ERN	DATE	CHC'D BY
-	4499	5/22/2020	RELSD

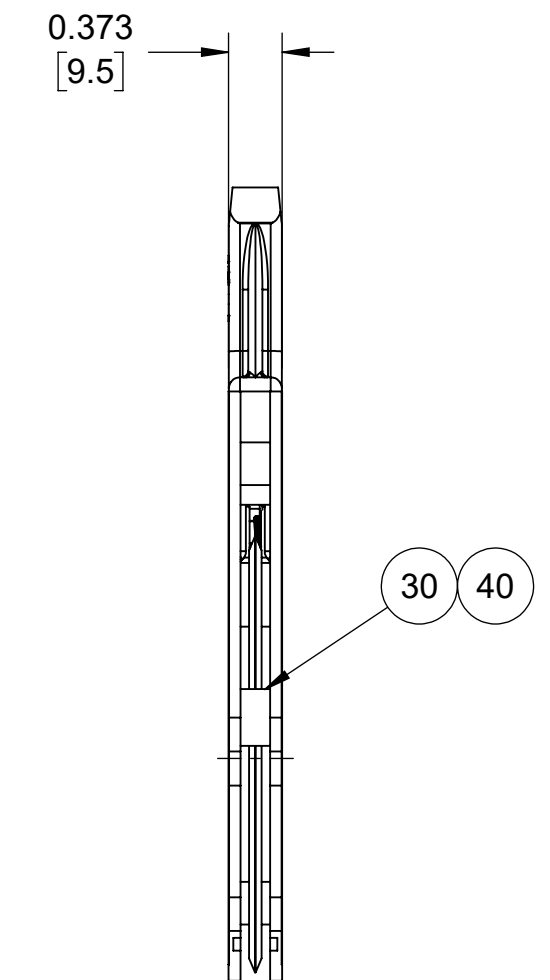
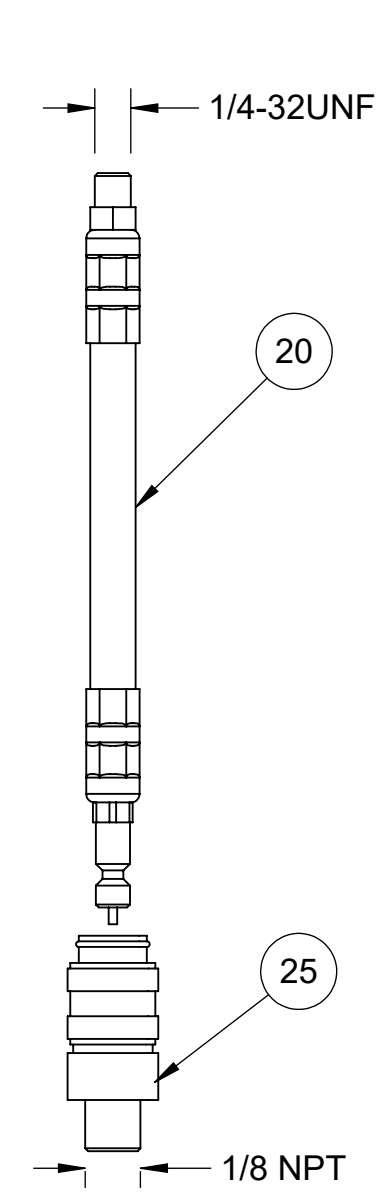
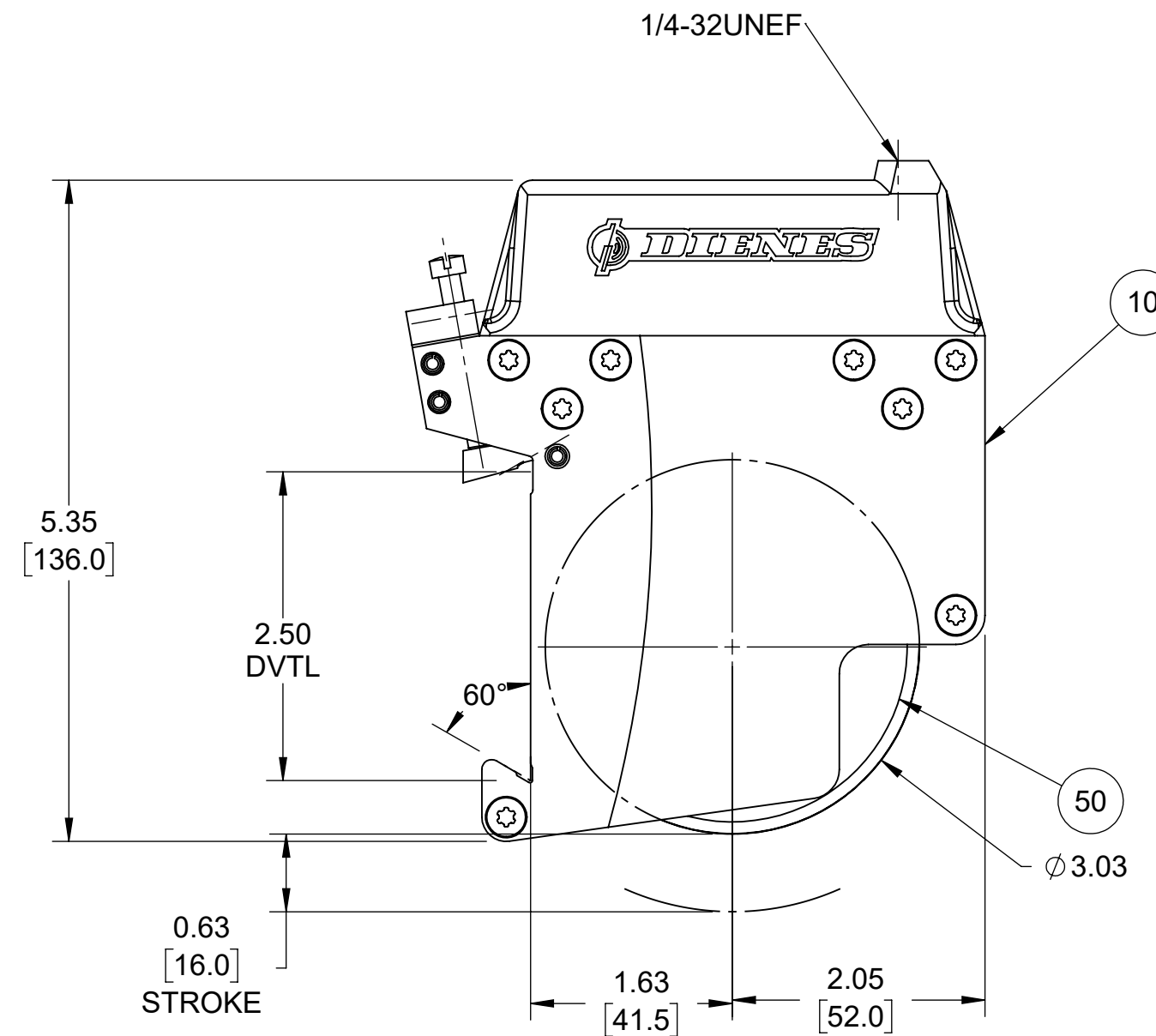
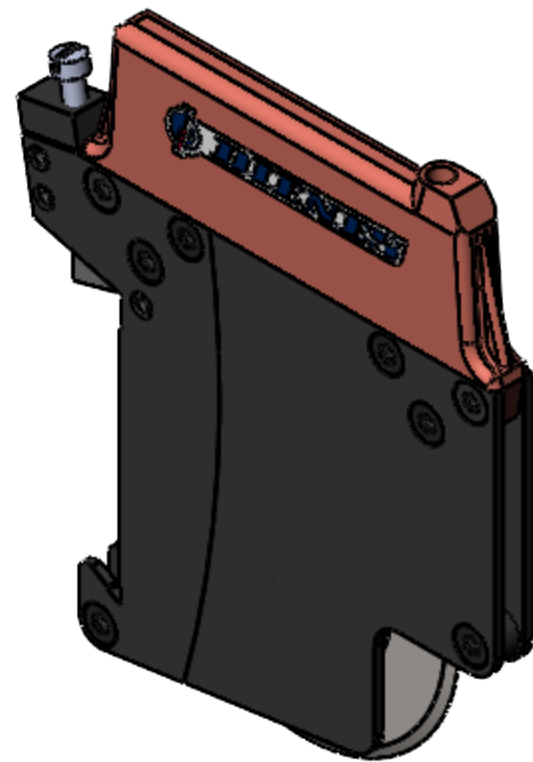

NOTES:

1. MATERIAL: SEE BILL OF MATERIAL.
2. THIS HOLDER IS STANDARD CONFIGURATION.
3. USE FIXTURE TO ENSURE HOLDER IS ASSEMBLED SQUARE, IF APPLICABLE
4. TEST HOLDER FOR STROKE & PNEUMATIC LEAKS.
5. APPROX. WEIGHT: 1.42 LBS
6. REF DW DWG 244A119B02001.

This document is the property of
Dienes Corporation
 It may contain proprietary information
 DO NOT USE FOR PURPOSES
 OTHER THAN THOSE INTENDED

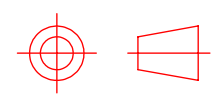
 US PROJECTION		DIENES CORPORATION <i>Spencer Massachusetts</i>	
REFERENCE METRIC DATA		HLDR,PQAS3/8",SCR,STD	
Unless Otherwise Noted Dimensions Are In Inches		Drawn by: BGB	Date: 05/22/2020
Tolerances Unless Noted: .XXX ±.005 .XX ±.010 FRACT. ±.015 ANGLE ±1/2° Finish Unless Noted: <input checked="" type="checkbox"/> 125		Checked by: BB	Date: 05/22/2020
DO NOT SCALE DRAWING		Scale: 3:4	Drawing Number: C02022-01
Sheet 1 of 2		Rev. -	
REF DWG: 02023-01		For Internal DIENES CORPORATION Use Only	

PQAS 3/8" Screw Clamp Score Cut Holder

Dienes No. 02022-01

ITEM NO.	PART NUMBER	DESCRIPTION	QTY.
1	02152-09	PRESSURE CYLINDER	1
2	02042-09	GASKET,PQAS 3/8"	1
3	02768	SIDEPLATE,RH (NON-REPLACEABLE)	1
4	02769	SIDEPLATE,LH(NON-REPLACEABLE)	1
5	02153-09	KNIFE FORK	1
6	02731	KNF,SCORE 3.0X.74X.204-45° 52	1
7	02043-09	PIN,BRG 3/8"	1
8	02133-09	DISTANCE RING,PQAS 3/8"	2
9	021208	INTERMEDIATE PIECE,PQAS 3/8"	2
10	02186	CLAMP BODY, PQAS 3/8"(8-32)	1
11	02154-09	SCR,FILLISTER HD, 8-32X1.5	1
12	021087	CLAMP ARM,PQAS 3/8"	1
13	02039-09	SPRG,PRESSURE	2
14	655384	PIN,TENSION 5/32 X 3/8	3
15	02132-09	SCR,CAP,FL TORX HD,M4X8,5	2
16	02591	BRG,BALL 5.2MM,SEALED	1
17	412414-01	SPRG,RETURN,PQAS/PQDS	1
18	33686-0015	LOGO,DECAL	1
19	02041-43	HOSE,AIR,TYPE 1 - 20" W/O CPLR	1
20	02120-09	COUPLER	1

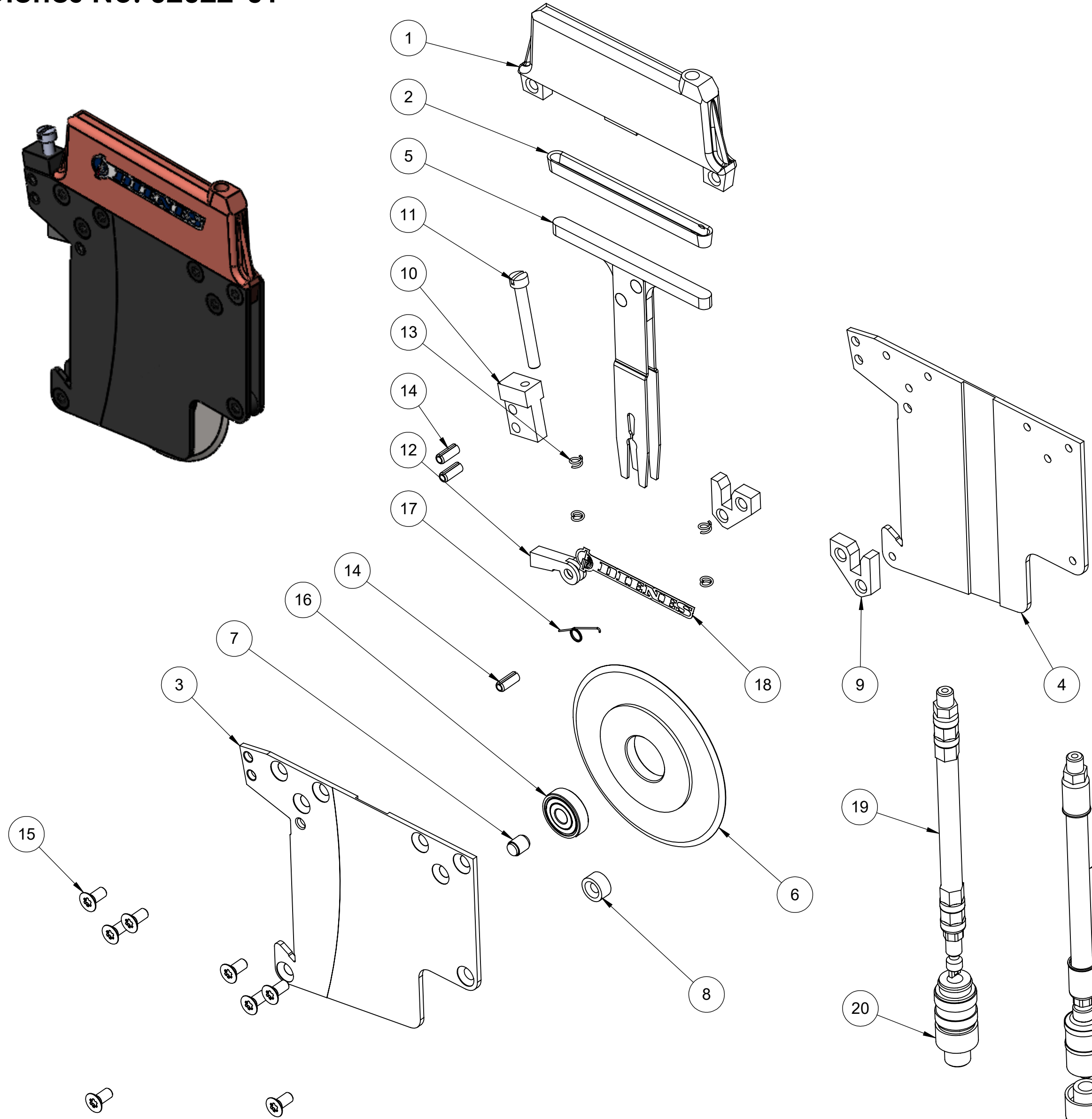

OPTIONAL:
AIR HOSE, TYPE 3 W/COUPLER
02298-09

OPTIONAL:
AIR HOSE, TYPE 1 W/COUPLER
02041-46

REF 1/8NPT COUPLER
02080-09

This document is the property of
Dienes Corporation
It may contain proprietary information
DO NOT USE FOR PURPOSES
OTHER THAN THOSE INTENDED

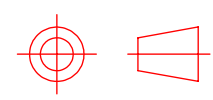
 US PROJECTION		DIENES CORPORATION <i>Spencer Massachusetts</i>	
REFERENCE METRIC DATA		HLDR,PQAS3/8",SCR,STD	
<small>Unless Otherwise Noted Dimensions Are In Inches</small>		<small>Drawn by:</small>	BGB
<small>Tolerances Unless Noted:</small>		<small>Date:</small>	05/22/2020
<small>.XXX ±.005</small>	<small>.XX ±.010</small>	<small>Checked by:</small>	BB
<small>FRACT. ±.015</small>	<small>ANGLE ±1/2°</small>	<small>Date:</small>	05/22/2020
<small>Finish Unless Noted:</small>	<small>125° ✓</small>	<small>Scale:</small>	3:4
<small>DO NOT SCALE DRAWING</small>		<small>Drawing Number</small>	C02022-01
<small>O.D.</small>	<small>I.D.</small>	<small>Sheet</small>	<small>of</small>
<small>THK.</small>	<small>REF DWG:</small>	2	2
22430	<small>For Internal DIENES CORPORATION Use Only</small>		