

0010	02843	1.00	EA	HLDR,PQA-MC2,1/2"
0020	02041-09	1.00	EA	HOSE,AIR,TYPE 1 - 20" W/CPLR
0030	02442	1.00	EA	KNF,SCORE 3.0X.74X.24-45° 52
0040	02698	1.00	EA	BRG,BALL 6X19X6
0050	02045-09	1.00	EA	PIN,BRG,1/2" HLDR 19MM BRG

REVISIONS			
REV.	ERN	DATE	CHC'D BY
-	4499	1/4/2021	RELSO

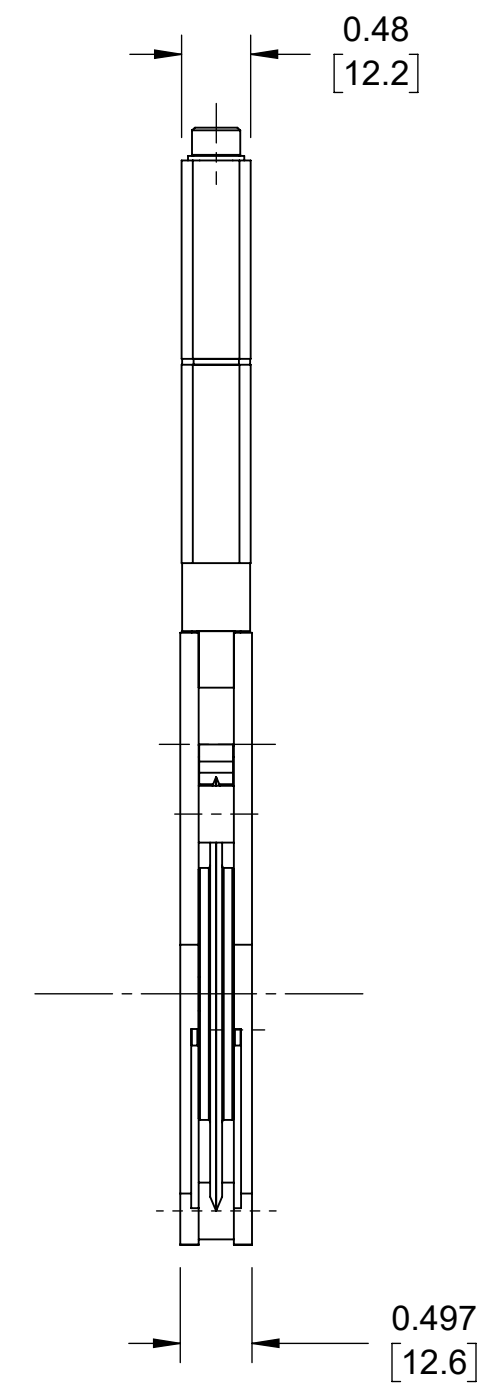
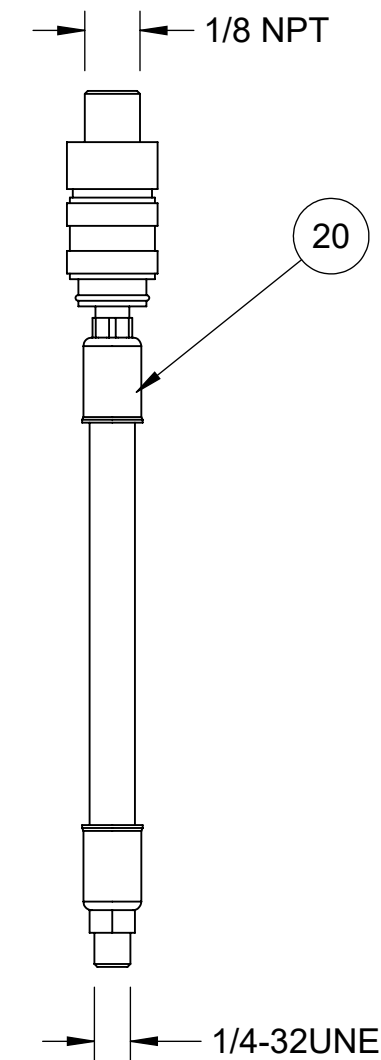
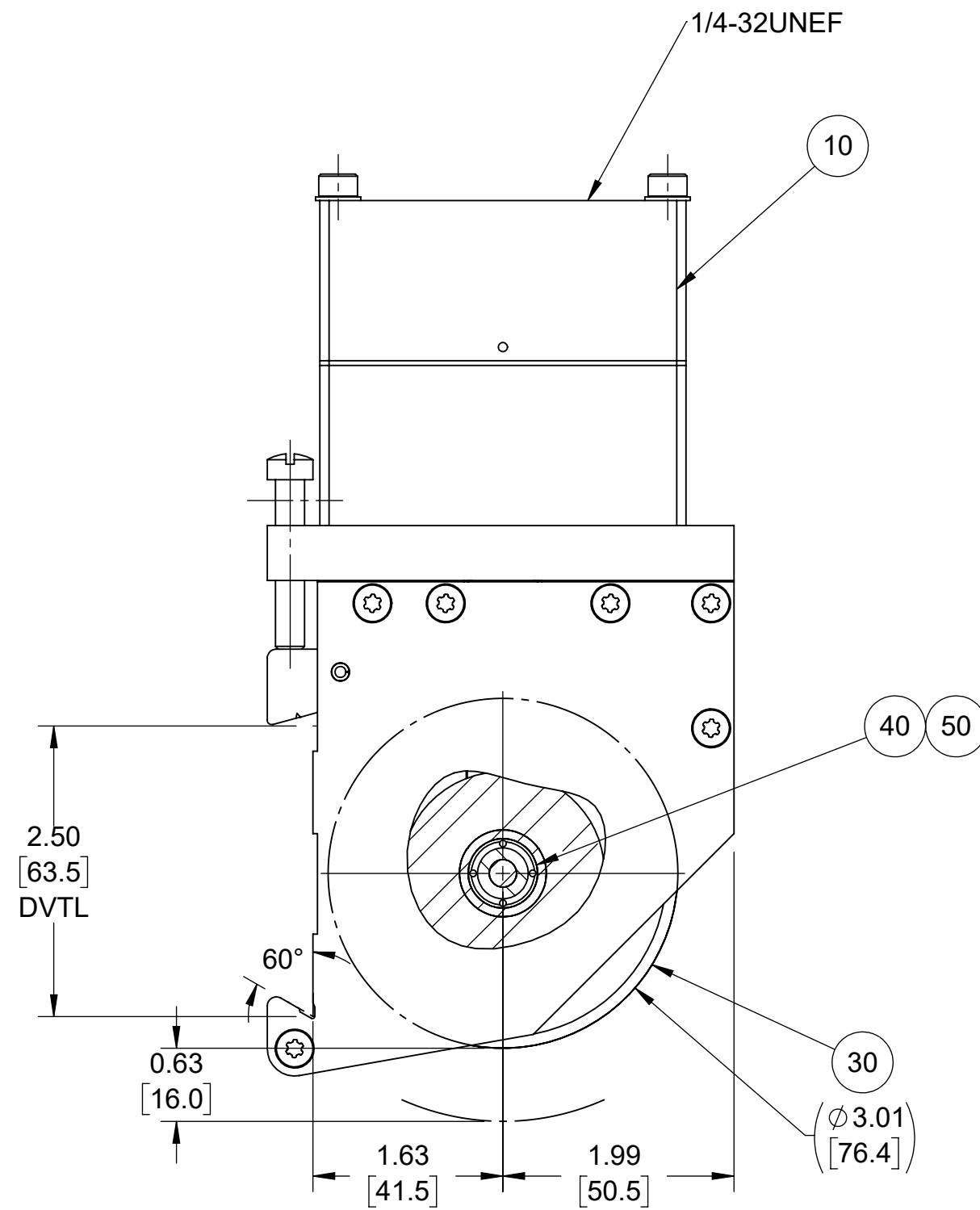
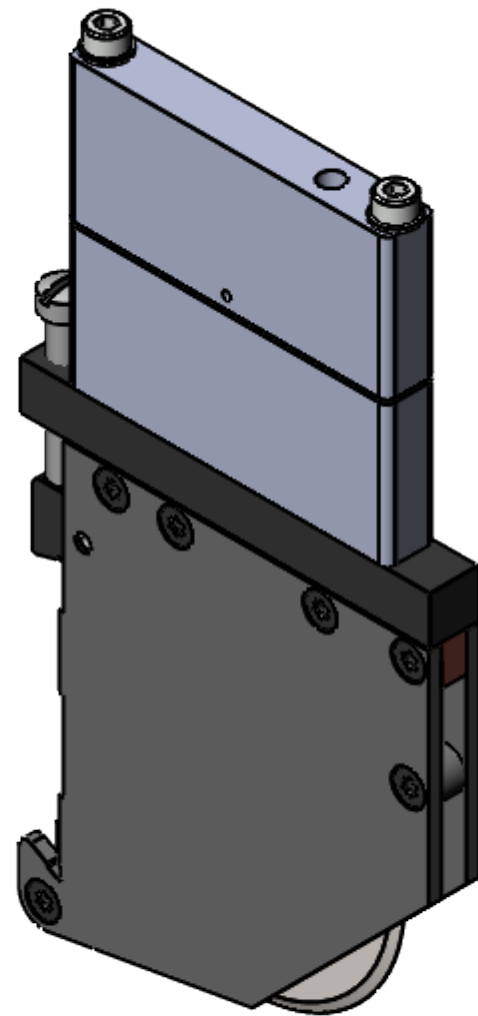

NOTES:

1. MATERIAL: SEE BILL OF MATERIAL.
2. THIS HOLDER IS STANDARD CONFIGURATION.
3. USE FIXTURE TO ENSURE HOLDER IS ASSEMBLED SQUARE, IF APPLICABLE
4. TEST HOLDER FOR STROKE & PNEUMATIC LEAKS.
5. APPROX. WEIGHT: 2.8 LBS
6. REF DW DWG 244A162C01001.

This document is the property of
Dienes Corporation
 It may contain proprietary information
 DO NOT USE FOR PURPOSES
 OTHER THAN THOSE INTENDED

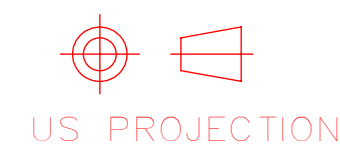

REFERENCE METRIC DATA DIM TOL		DIENES CORPORATION Spencer Massachusetts	
		HLDR,PQA-MC-HP,1/2"	
O.D.		Unless Otherwise Noted Dimensions Are In Inches	Drawn by: BGB
I.D.		Tolerances Unless Noted: .XXX ±.005 .XX ±.010 FRACT. ±.015 ANGLE ±1/2° Finish Unless Noted: 125 ✓	Date: 01/04/2021
THK.		DO NOT SCALE DRAWING	Checked by: BB
REF DWG: 02393		Sheet 1 of 2	Date: 01/04/2121
		Drawing Number C02024-01	Scale: 3:4
		For Internal DIENES CORPORATION Use Only	
			Rev. -

PQA-MC2 HP Score Cut Holder
Dienes No. 02024-01

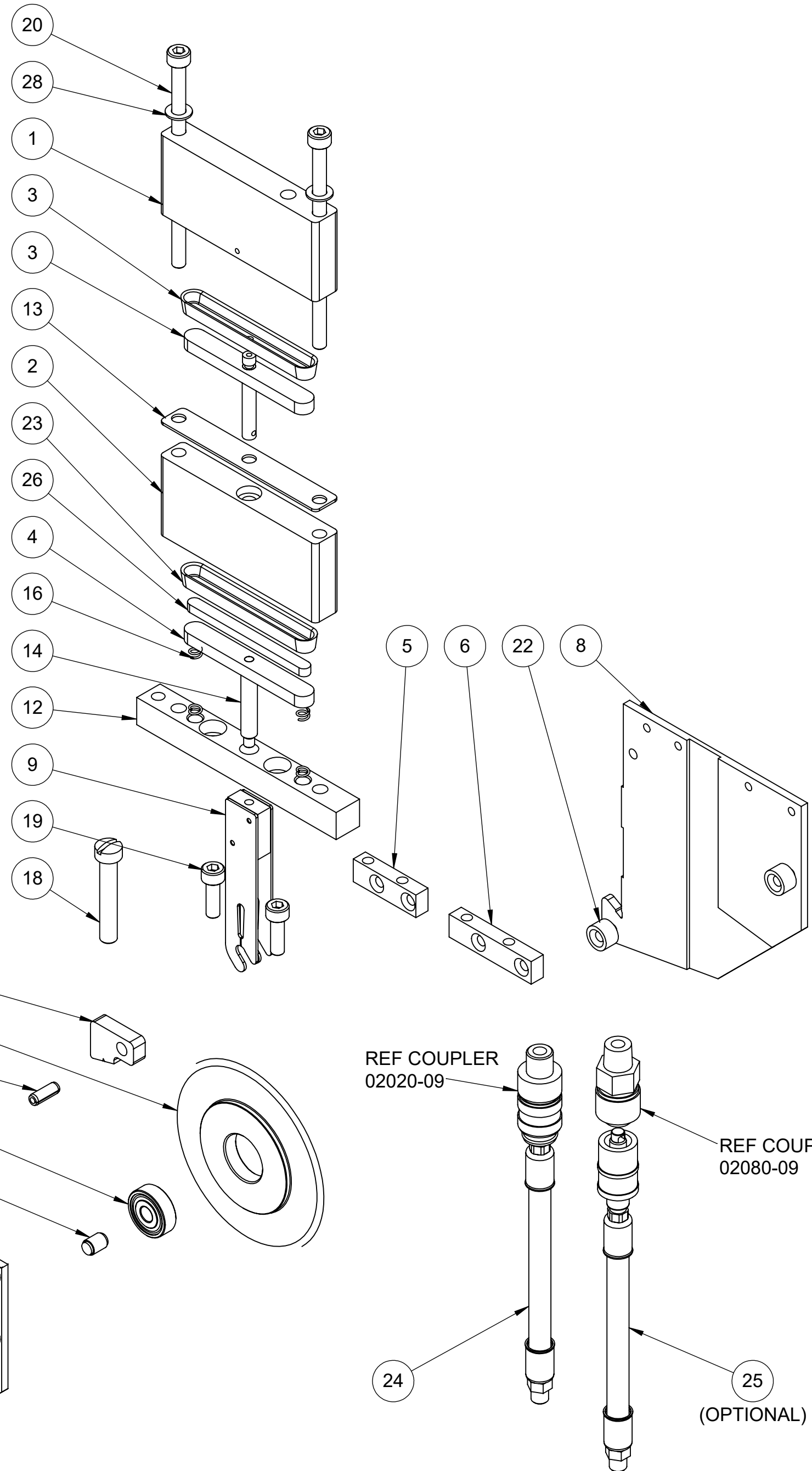
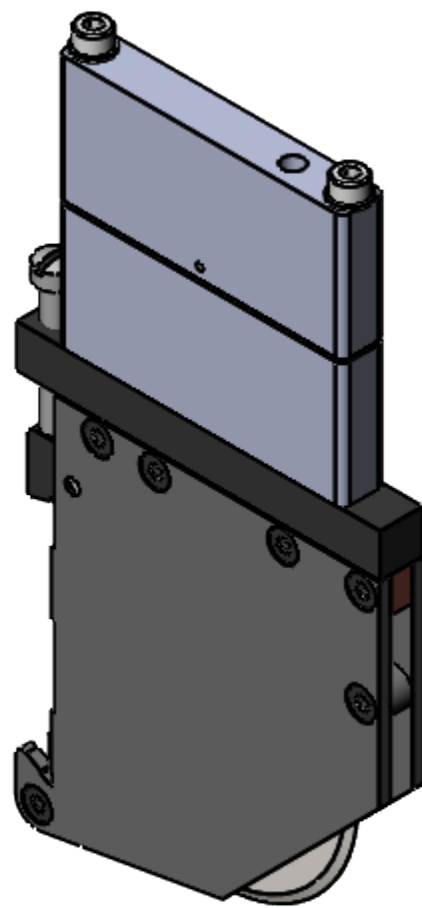

ITEM NO.	PART NUMBER	DESCRIPTION	QTY
1	02428	CYLINDER,PRESSURE - PQAMC	1
2	02426	CYLINDER,PRESSURE - PQAMC	1
3	02666	PRESSURE PISTON PQA-MC-HP	1
4	021314	PRESSURE PISTON #4 PQA-MC2	1
5	02176	INTERMEDIATE PIECE #5	1
6	02390	INTERMEDIATE PIECE #6	1
7	021052	SHEET,SIDE - RH-NOT FOR RESALE	1
8	021053	SHEET,SIDE - LH-NOT FOR RESALE	1
9	02389	KNIFE FORK FOR PQA-MC-HP	1
10	02442	KNF,SCORE 3.0X.74X.24-45° 52	1
11	02045-09	PIN,BRG,1/2" HLDR 19MM BRG	1
12	02216	CLAMPING FLUTE FOR PQA-MC-HP	1
13	02094-09	INTERMEDIATE PLATE	1
14	02705	PIN,THD	1
15	02237	CLAMPING PIECE FOR PQA-MC	1
16	02039-09	SPRG,PRESSURE	2
17	02698	BRG,BALL 6X19X6	1
18	653732	SCR,FILLISTERHD,1/4-20X1.5 S.S.	1
19	613566	SCR,CAP,SOC HD,M5X16 FS	2
20	613598	SCR,CAP,SOC HD,M5X90	2
21	02095-09	SCR,CAP,FL TORX HD,M4X12,BLK	6
22	02038-09	RING,DISTANCE - PQAS 1/2"	2
23	02087-09	GASKET	1
24	02041-09	HOSE,AIR,TYPE 1 - 20" W/CPLR	1
25	02298-09	HOSE,AIR,TYPE 3 - 20" W/CPLR	1
26	02667	SHIM,PQAMC (3.5mm)	1
27	02777	PIN,SPRING M4x12	1
28	615722	WASH,PLAIN,M5 FS	2

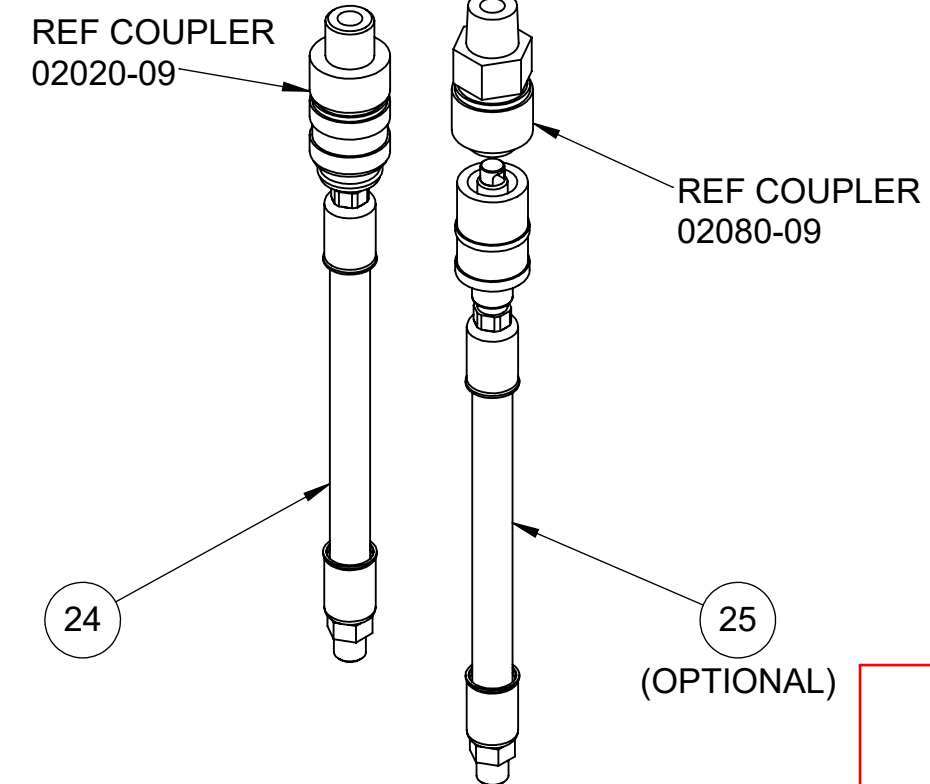

This document is the property of
Dienes Corporation
 It may contain proprietary information
 DO NOT USE FOR PURPOSES
 OTHER THAN THOSE INTENDED

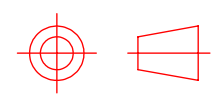
 US PROJECTION		DIENES CORPORATION <i>Spencer Massachusetts</i>	
HLDR,PQA-MC-HP, 1/2"		Drawn by: BGB	Date: 01/04/2021
REFERENCE METRIC DATA		Checked by: BB	Date: 01/04/2121
DIM	TOL	Scale: 2:3	Drawing Number: C02024-01
O.D.		Finish Unless Noted: <input checked="" type="checkbox"/>	Rev: -
I.D.		DO NOT SCALE DRAWING	
THK.		Sheet 2 of 2	
REF DWG:		For Internal DIENES CORPORATION Use Only	