

REVISIONS			
REV.	ERN	DATE	CHC'D BY
-	4499	2/5/2021	RELSO

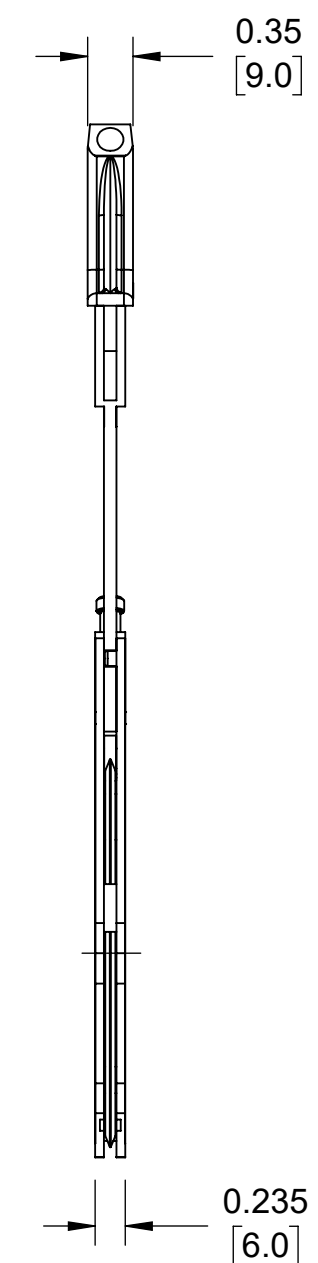
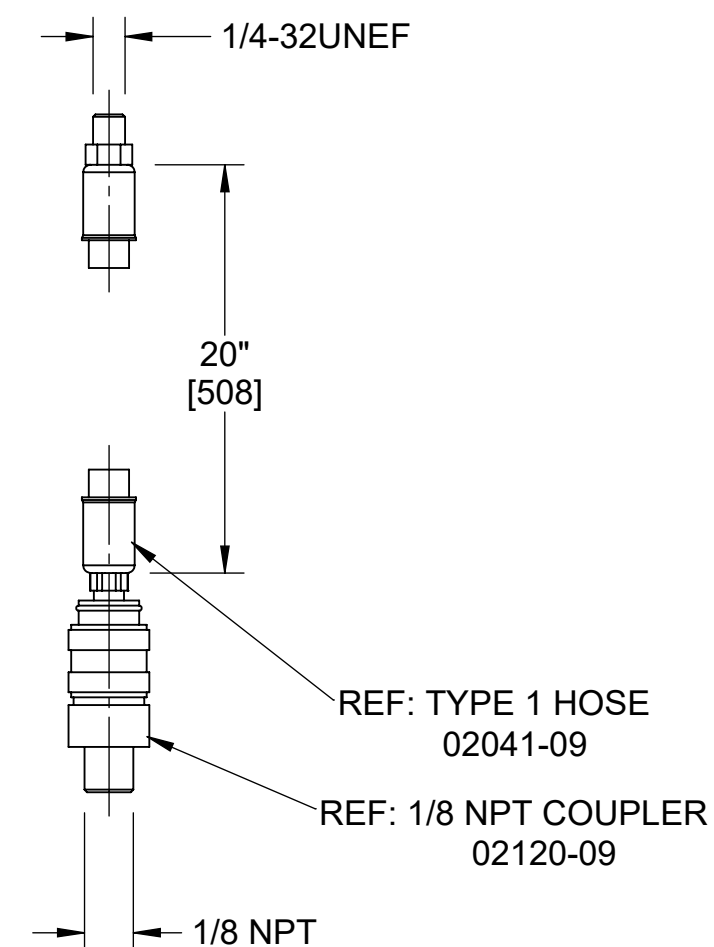
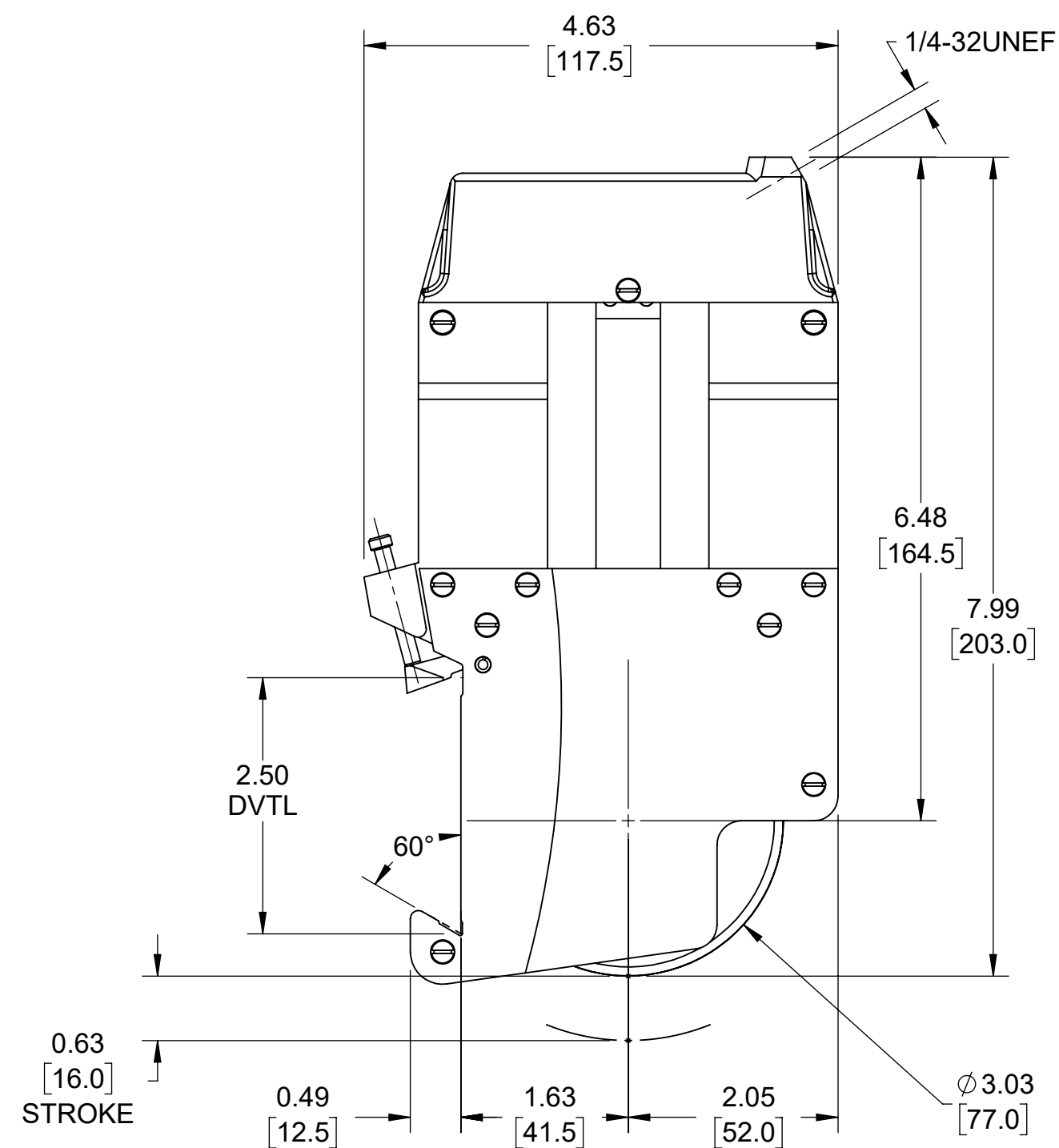
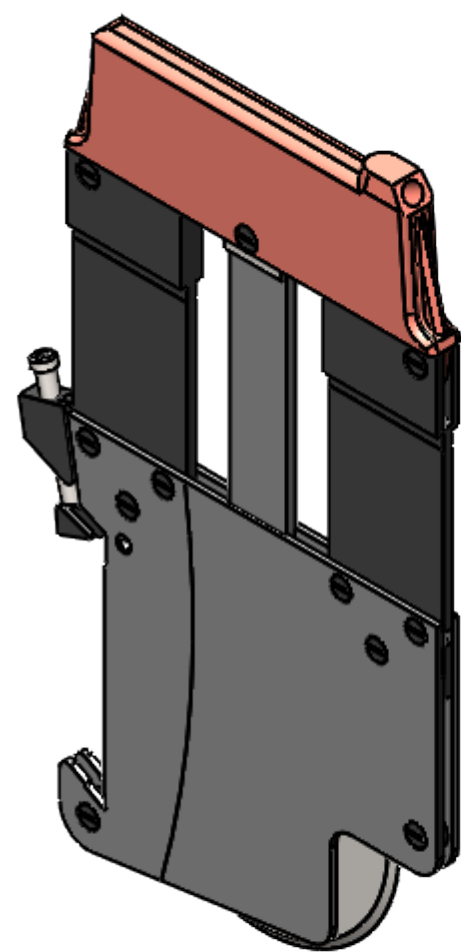

NOTES:

1. MATERIAL: SEE BILL OF MATERIAL.
2. THIS HOLDER IS STANDARD CONFIGURATION.
3. USE FIXTURE TO ENSURE HOLDER IS ASSEMBLED SQUARE, IF APPLICABLE
4. TEST HOLDER FOR STROKE & PNEUMATIC LEAKS.
5. APPROX. WEIGHT: 1.5 LBS
6. THIS DRAWING FOR REFERENCE ONLY
SEE DW DRAWING 244A157B02001.

This document is the property of
Dienes Corporation
It may contain proprietary information
DO NOT USE FOR PURPOSES
OTHER THAN THOSE INTENDED

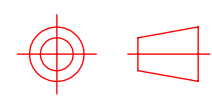
 US PROJECTION		DIENES CORPORATION <i>Spencer Massachusetts</i>	
HLDR, PQAS6MM, LONG		Drawing Number C021116	
REFERENCE METRIC DATA		Drawn by: BGB	
DIM TOL		Date: 02/05/2021	
O.D.		Checked by: BB	
I.D.		Date: 02/05/2021	
THK.		Scale: 2:3	
REF DWG: 02023-01		For Internal DIENES CORPORATION Use Only	

Unless Otherwise Noted Dims in Inches
 Tolerances Unless Noted:
 .XXXX ±.0005
 .XXX ±.005
 .XX ±.010
 .X ±.015
 ANGLE ±1/2°
 Finish Unless Noted: 125
 DO NOT SCALE DRAWING
 Sheet **1** of **2**

Rev.
-

PQAS 6MM Score Cut Holder (Long)

Dienes No. 021116

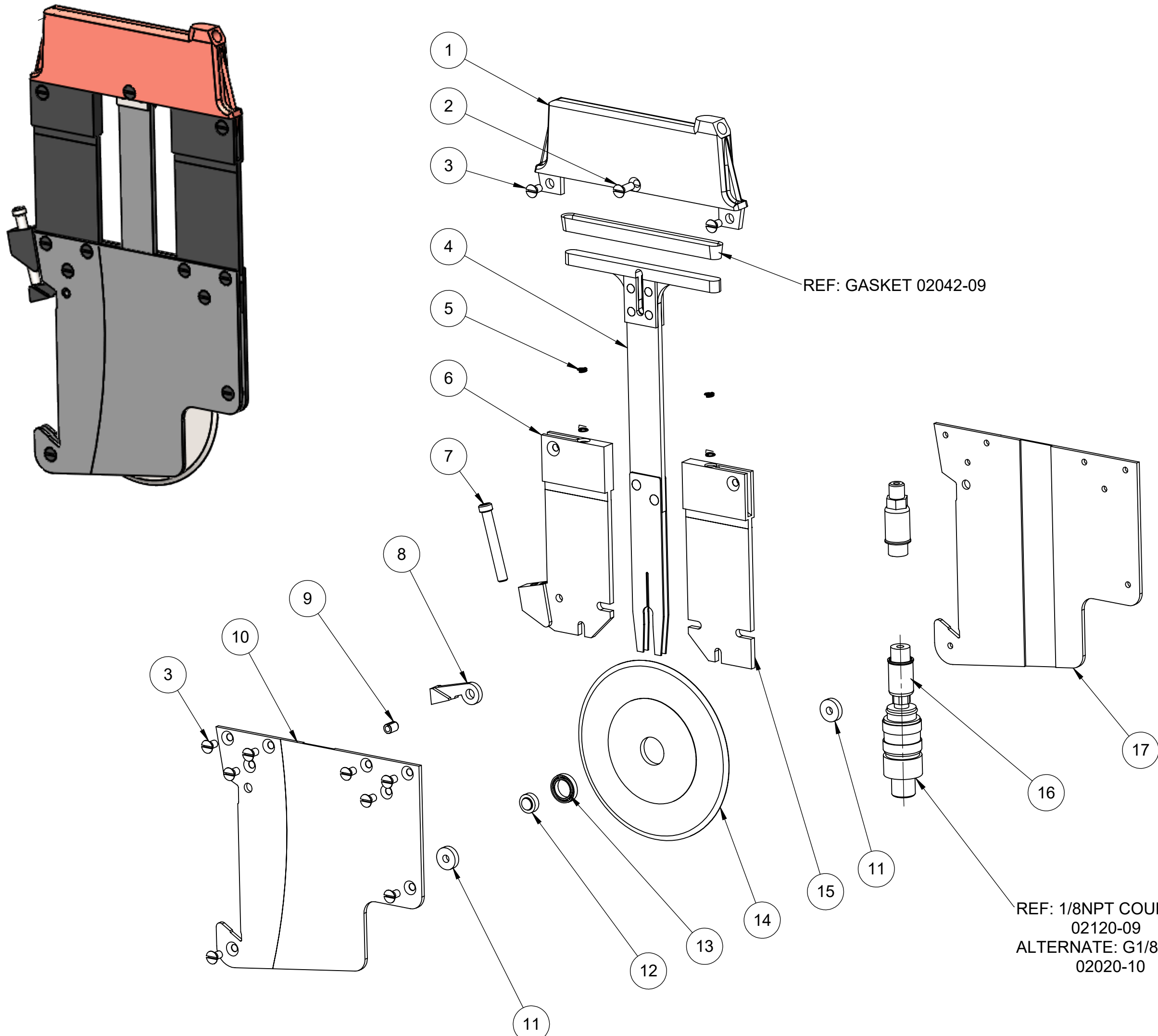

ITEM NO.	PART NUMBER	DESCRIPTION	QTY.
1	02443	CYLINDER,PRESS,W/GASKET	1
2	234B010176020	SCR,C'SINK,M3X9	1
3	234B010176010	SCR,C'SINK,M3X5.5	10
4	02198	KNIFE FORK-PQAS,6MM HIGH	1
5	021167	SPRG,RETURN	2
6	244B297A01001	INTERM,CLAMPING PIECE	1
7	613522	SCR,CAP,SOC HD,M4X30	1
8	021670	CLAMPING PIECE	1
9	616364	PIN,SPRING,M4X6 (GRIND TO 5.5MM LONG)	1
10	244B110578020	LH PLATE (NON REPLACEABLE)	1
11	244B010287010	RING,DISTANCE,PQAS 6MM	2
12	02047-09	PIN,BRG 8MM O.D.	1
13	02046-09	BRG,BALL,12X8X2.5	1
14	22054	KNF,SCORE	1
15	244B090864010	INTERM,CLAMPING PIECE	1
16	02041-09	HOSE,AIR,TYPE 1 - 20" W/CPLR	1
17	244B110579020	RH PLATE (NON REPLACEABLE)	1

This document is the property of
Dienes Corporation
 It may contain proprietary information
 DO NOT USE FOR PURPOSES
 OTHER THAN THOSE INTENDED

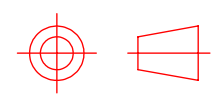
 US PROJECTION		DIENES CORPORATION <i>Spencer Massachusetts</i>	
HLDR,PQAS6MM,LONG		Drawn by: BGB	
REFERENCE METRIC DATA		Tolerances Unless Noted: .XXX ±.0005 .XX ±.005 .X ±.010 FRACT: ±.015 ANGLE: ±1/2° Finish Unless Noted: <input checked="" type="checkbox"/>	
O.D.	TOL	Date:	02/05/2021
I.D.		Checked by:	BB
THK.		Date:	02/05/2021
REF DWG:		Scale:	2:3
		Drawing Number C021116	
		Rev. -	
For Internal DIENES CORPORATION Use Only			