

PQAS 1/2" Screw Clamp Score Cut Holder

Dienes No. 02023-01

ITEM NO.	PART NUMBER	DESCRIPTION	QTY.
1	02032-09	CYLINDER,PRESSURE - PQAS	1
2	02769	PQAS LH Sideplate (Thd holes)	1
3	02768	PQAS RH Sideplate (C'bore'd holes)	1
4	02034-09	PQAS 1/2" Knife Fork	1
5	02599	Intermediate Piece	2
6	02035-09	Bearing Pin	1
7	02254	Knf,Crushcut 3.03X0.866X.244	1
8	02033-09	Gasket,Bladder PQAS 1/2"	1
9	02037-09	PQAS 1/2-Clamp Arm	1
10	02036-09	PQAS Clamp Body	1
11	33686-0015	LOGO,DECAL	1
12	02777	PIN,SPRING M4x12	3
13	02038-09	Distance Ring	2
14	02676-11	BRG,BALL,SEALED 8X22X6	1
15	02039-09	SPRING,PRESSURE	2
16	02041-09	HOSE,AIR,TYPE 1 - 20" W/CPLR	1
17	02125-09	SCR,FILLISTER HD,12-24X1.5 LG	1
18	02095-09	SCR,CAP,FL TORX HD,M4x12	7
19	412414-01	SPRG,RETURN,PQAS/PQDS	1
20	222158-10	CLAMP ASSY,1/2PQAS,(10-24 SCR)	1
21	02298-09	HOSE,AIR,TYPE 3, 20"W/CPLR	1

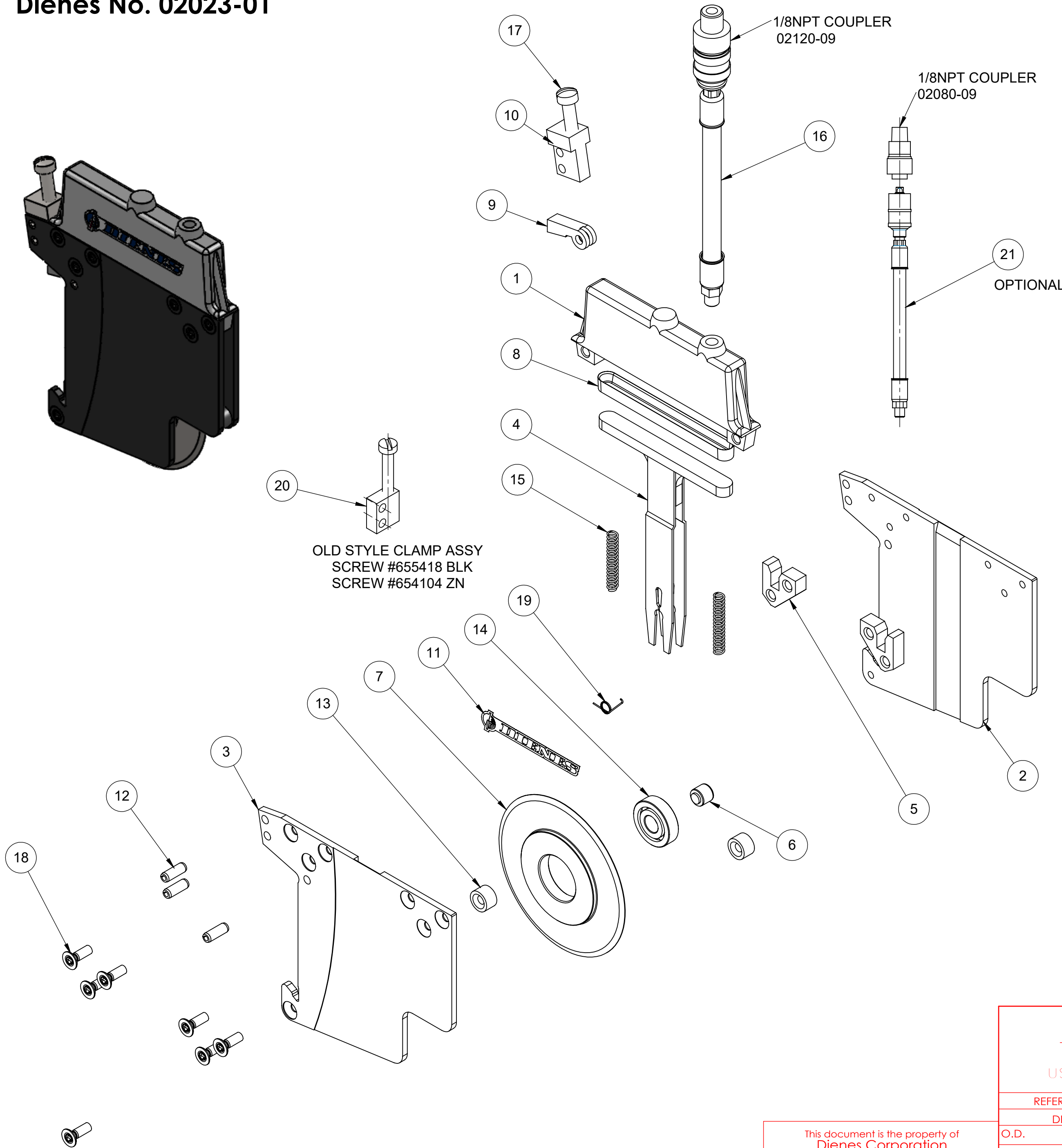

This document is the property of
Dienes Corporation
 It may contain proprietary information
 DO NOT USE FOR PURPOSES
 OTHER THAN THOSE INTENDED

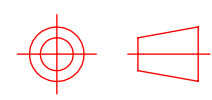
 US PROJECTION		DIENES CORPORATION <i>Spencer Massachusetts</i>	
HLDR,PQAS1/2",STD,SCR FIX		Drawn by: BGB Date: 05/12/2020	Checked by: BB Date: 05/12/2020
REFERENCE METRIC DATA		Unless Otherwise Noted Dimensions Are In Inches Tolerances Unless Noted: .XXX ±.005 .XX ±.010 FRACT. ±.015 ANGLE ±1/2° Finish Unless Noted: <input checked="" type="checkbox"/> 125	Scale: 3:4 Drawing Number: C02023-01 Rev. -
DIM.	TOL.	DO NOT SCALE DRAWING Sheet 2 of 2	
O.D.		REF DWG: 22300	
I.D.		For Internal DIENES CORPORATION Use Only	
THK.			