

0010	419582	1.00	EA	HLDR,PQA-HI SPEED 1/2",PARTIAL
0020	244A177001001	1.00	EA	KNIFE FORK,PQAS1/2",FRONT LOAD
0030	023806-10	2.00	EA	SPRG,PRESSURE,32MM,MUSIC
0040	418227	1.00	EA	KNF,SCORE 3.0X2.046X.276,D2
0050	418273	1.00	EA	ASSY,CARRIER,KNF,PQA-HI SP
0060	418306	1.00	EA	CYLINDER,PRESSURE - PQAS HI-SP
0065	02095-09	2.00	EA	SCR,CAP,FL TORX HD,M4X12,BLK
0070	02033-09	1.00	EA	GASKET,PQAS/PQDS,1/2"
0080	02041-25	1.00	EA	HOSE,AIR,TYPE 1- 20" FLO-RESTR
0090	33686-0015	1.00	EA	LOGO DECAL 11.3MM X 70MM NEW

(A)

REVISIONS			
REV.	ERN	DATE	CHC'D BY
-	4053	5/16/13	RELSD
A	4593	3/2/2021	BGB

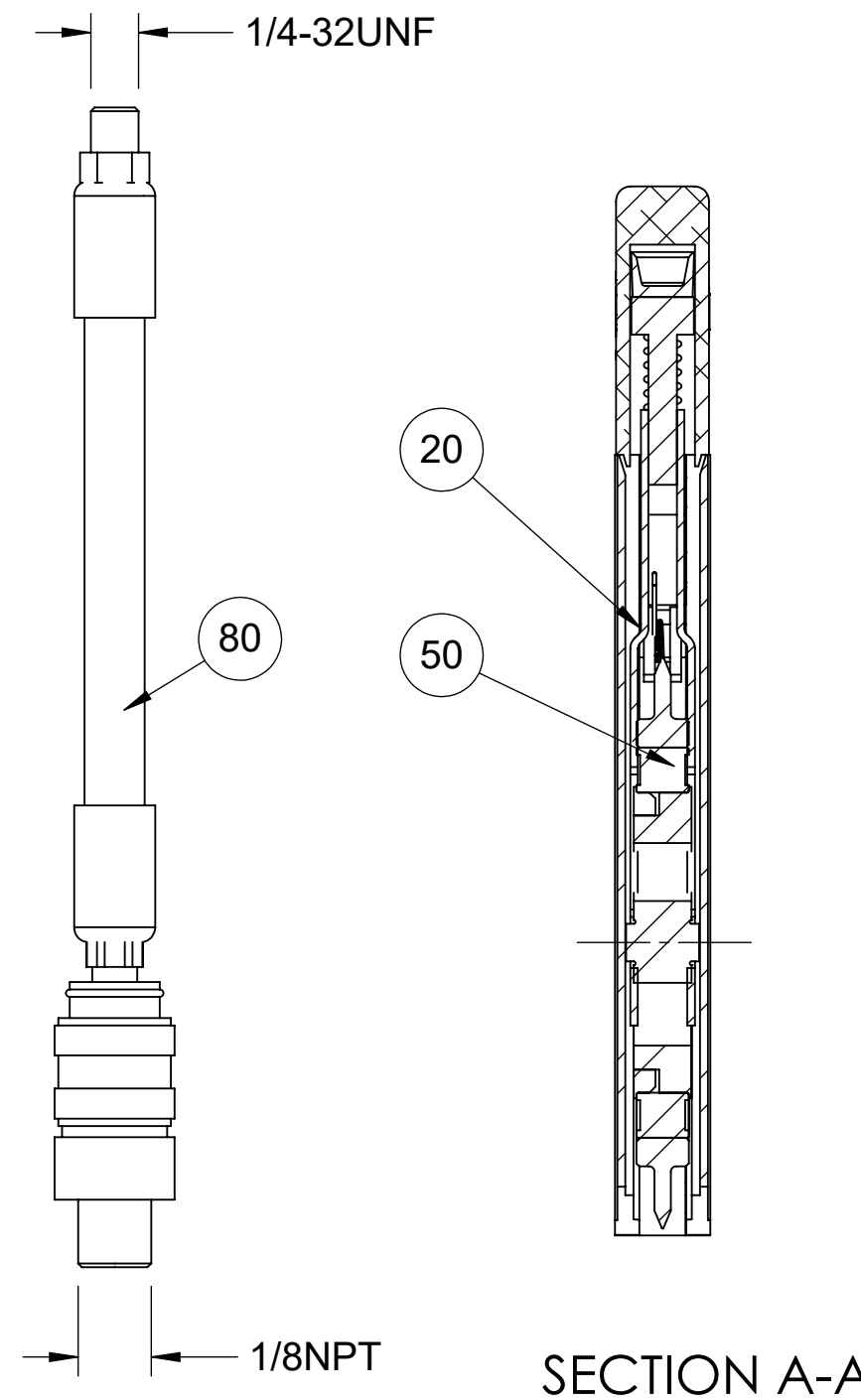
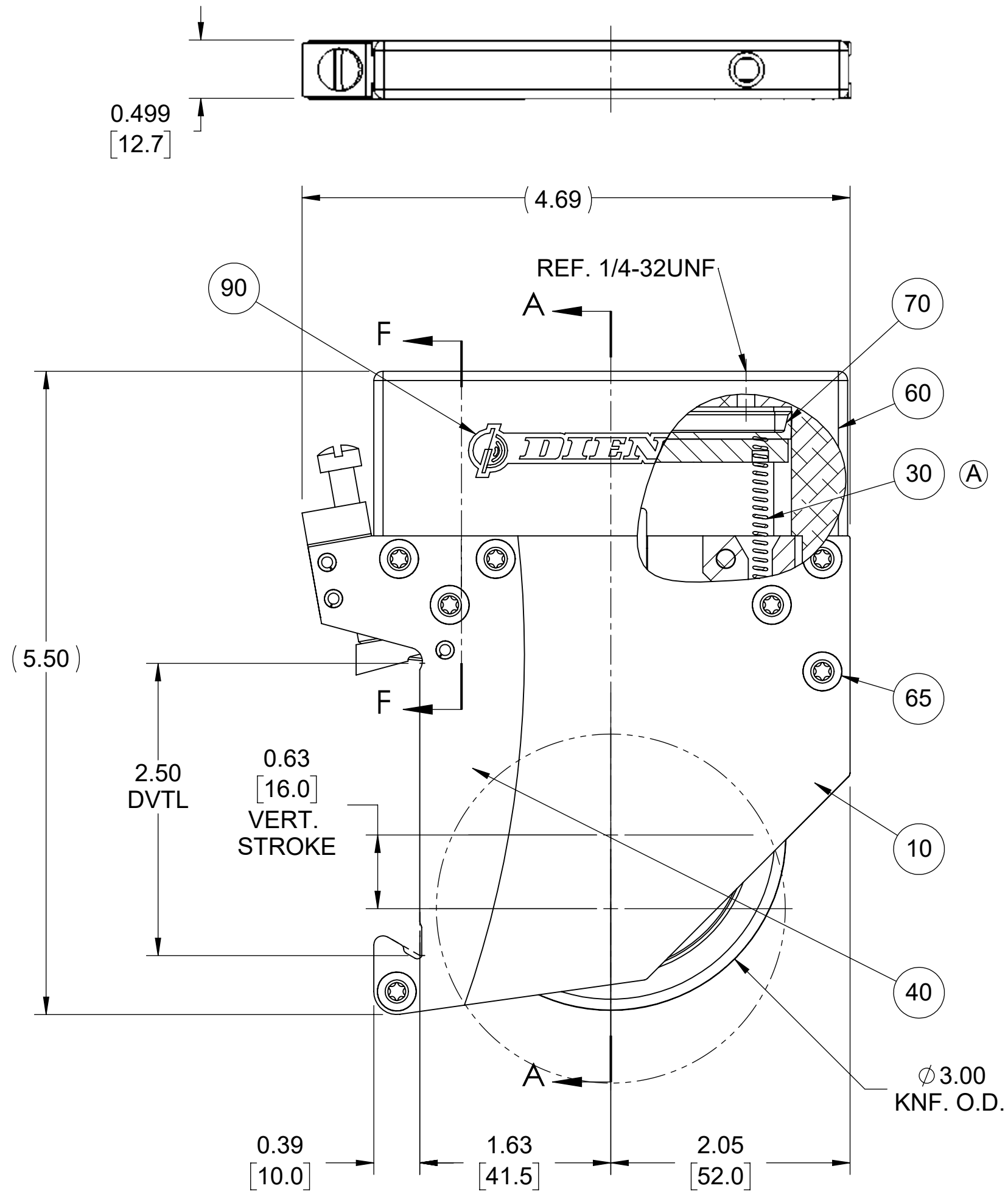
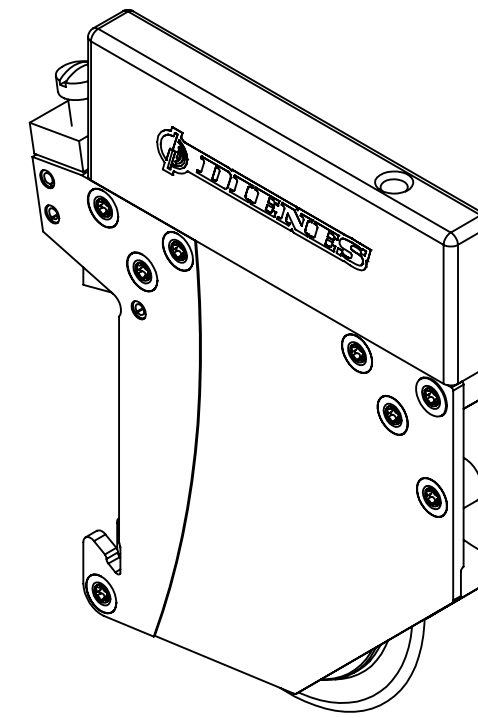

NOTES:

1. MATERIAL: SEE BILL OF MATERIAL.
2. THIS HOLDER IS STANDARD CONFIGURATION.
3. USE FIXTURE TO ENSURE HOLDER IS ASSEMBLED SQUARE, IF APPLICABLE
4. TEST HOLDER FOR STROKE & PNMEUMATIC LEAKS.
5. APPROX. WEIGHT: 1.66 LBS

This document is the property of  
**Dienes Corporation**  
 It may contain proprietary information  
 DO NOT USE FOR PURPOSES  
 OTHER THAN THOSE INTENDED

REFERENCE METRIC DATA	
DIM	TOL
O.D.	
I.D.	
THK.	

**DIENES CORPORATION**  
*Spencer Massachusetts*

**HLDR,PQAS HI-SPEED,1/2",SCR**

Unless Otherwise Noted Dimensions Are In Inches	Drawn by:	ARC
Tolerances Unless Noted:	Date:	5/7/2013
.XXX ±.005	Checked by:	AC
.XX ±.010	Date:	5/7/2013
FRACT. ±.015	Scale:	1:1
ANGLE ±1/2°	Finish Unless Noted: ✓	
DO NOT SCALE DRAWING	Drawing Number	CP2045-0002
Sheet 1 of 2	Rev.	A

For Internal DIENES CORPORATION Use Only

**PQAS Hi-Speed 1/2" Screw Clamp Score Cut Holder**  
**Dienes No. P2045-0002**

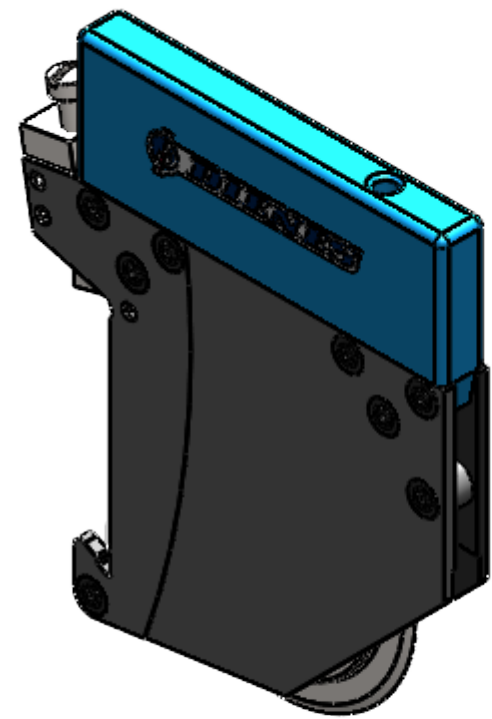

ITEM NO.	PART NUMBER	DESCRIPTION	QTY.
10	418306	PQAS PRESSURE CYLINDER	1
20	419582	HLDR,PQA-HI SPEED 1/2" PARTIAL	1
30	02033-09	GASKET,BLADDER PQAS 1/2"	1
40	418273	KNF, CARRIER ASSY, PQA-HI SP	1
50	418227	KNF,CRUSH,3X2.047X0.276,D2	1
60	33686-0015	LOGO,DECAL	2
70	02041-25	HOSE,AIR,TYPE 1-20"FLO-RESTR	1
80	023806-10	SPRING,PRESSURE,32MM,MUSIC	2
90	02095-09	SCR,CAP,FL TORX HD,M4X12	2
100	244A177001001	KNIFE FORK,PQAS,FRONT LOAD	1

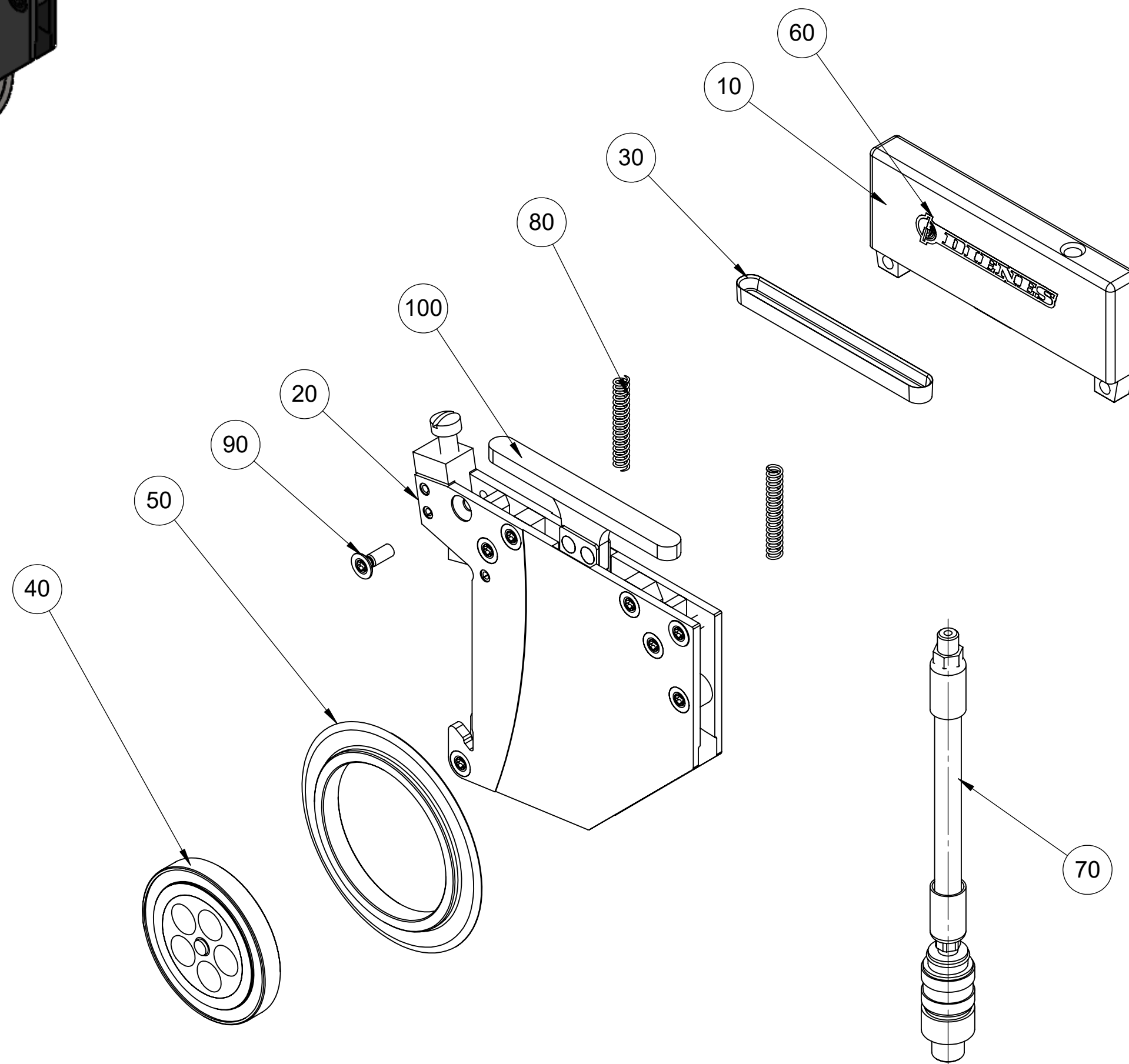

US PROJECTION

REFERENCE METRIC DATA

DIM	TOL
O.D.	
I.D.	
THK.	
REF DWG:	02023-01

**DIENES CORPORATION**  
*Spencer Massachusetts*

**HLDR,PQAS HI-SPEED,1/2",SCR**

Unless Otherwise Noted Dimensions Are In Inches	Drawn by:	ARC
Tolerances Unless Noted:	Date:	5/7/2013
.XXX ±.005	Checked by:	AC
.XX ±.010	Date:	5/7/2013
FRACT. ±.015	Scale:	3:4
ANGLE ±1/2°	DO NOT SCALE DRAWING	
Finish Unless Noted: <input checked="" type="checkbox"/> 125	Sheet <u>2</u> of <u>2</u>	Drawing Number <b>CP2045-0002</b>
		Rev. <b>A</b>

This document is the property of  
**Dienes Corporation**  
 It may contain proprietary information  
 DO NOT USE FOR PURPOSES  
 OTHER THAN THOSE INTENDED

For Internal DIENES CORPORATION Use Only