

02032-09	-1.00	EA	CYLINDER,PRESSURE-PQAS 1/2
02034-09	-1.00	EA	KNIFE FORK
02035-09	-1.00	EA	PIN,BRG,1/2" HLDR 22MM BRG
02039-09	-1.00	EA	SPRG,PRESSURE,30MM,ST STL
02041-09	-1.00	EA	HOSE,AIR,TYPE 1 - 20" W/CPLR
02254	-1.00	EA	KNF,SCORE 3.0X.86X.24-45° 52
02599	-1.00	EA	INTERMEDIATE PIECE PQAS 1/2"
02676	-1.00	EA	BRG,BALL,OPEN 8X22X6
0010 02023-01	1.00	EA	HLDR,PQAS1/2",STD,SCR FIX
0020 418147	1.00	EA	ASSY,SLIDE, RAZ HLDR
0040 418018	1.00	EA	SPACER BLOCK
0050 416792	1.00	EA	STUD,LOCATING PIN
0060 418017	1.00	EA	KNOB,LOCATING PIN
0080 655062	1.00	EA	RING,RETAINING,EXT Ø0.125
0110 02913	1.00	EA	KNF,RAZOR 1.69 X.875 X.008

REVISIONS			
REV.	ERN	DATE	CHC'D BY
B	4028	6/21/12	DB
C	4040	9/13/2012	ARC

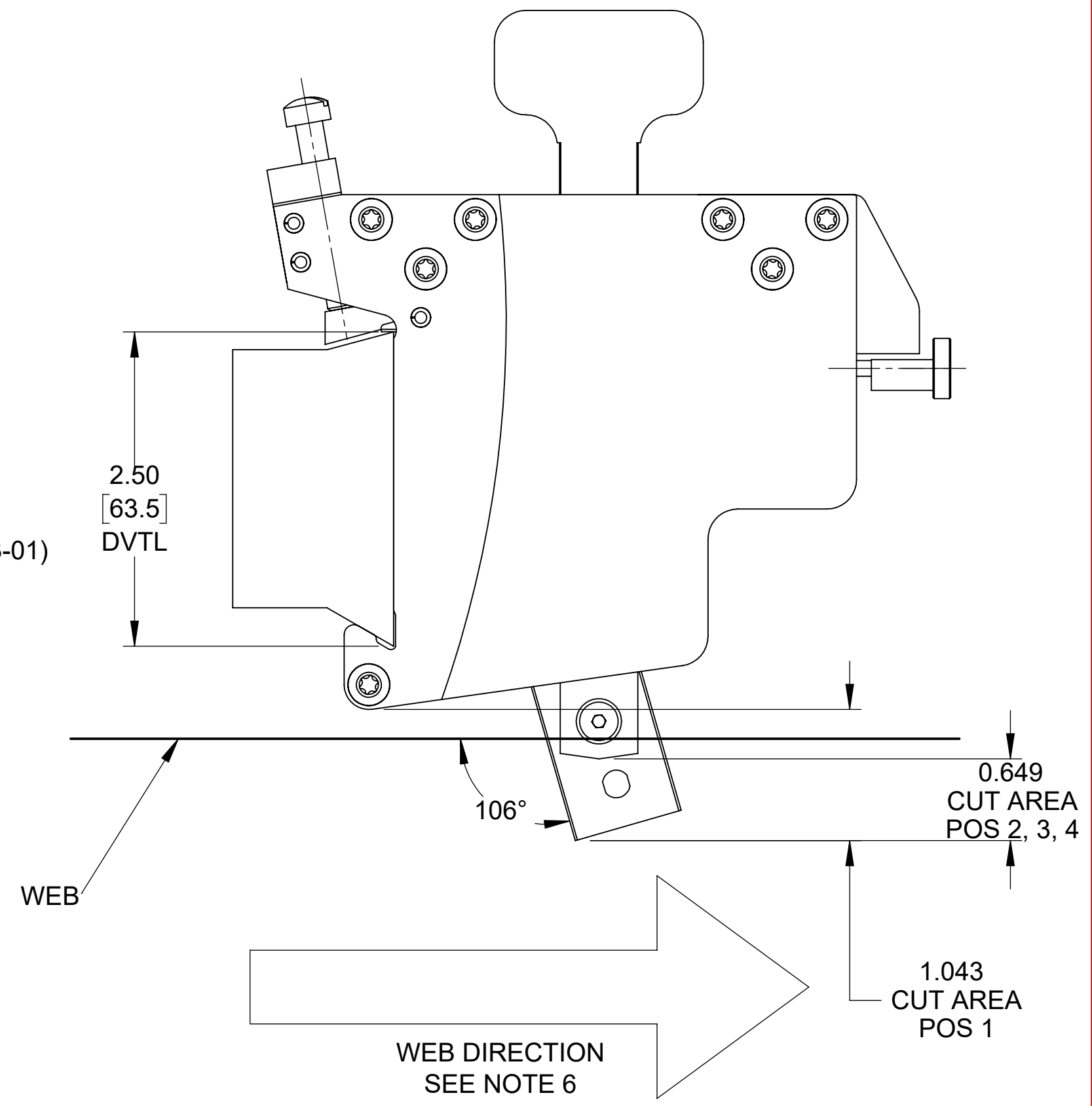
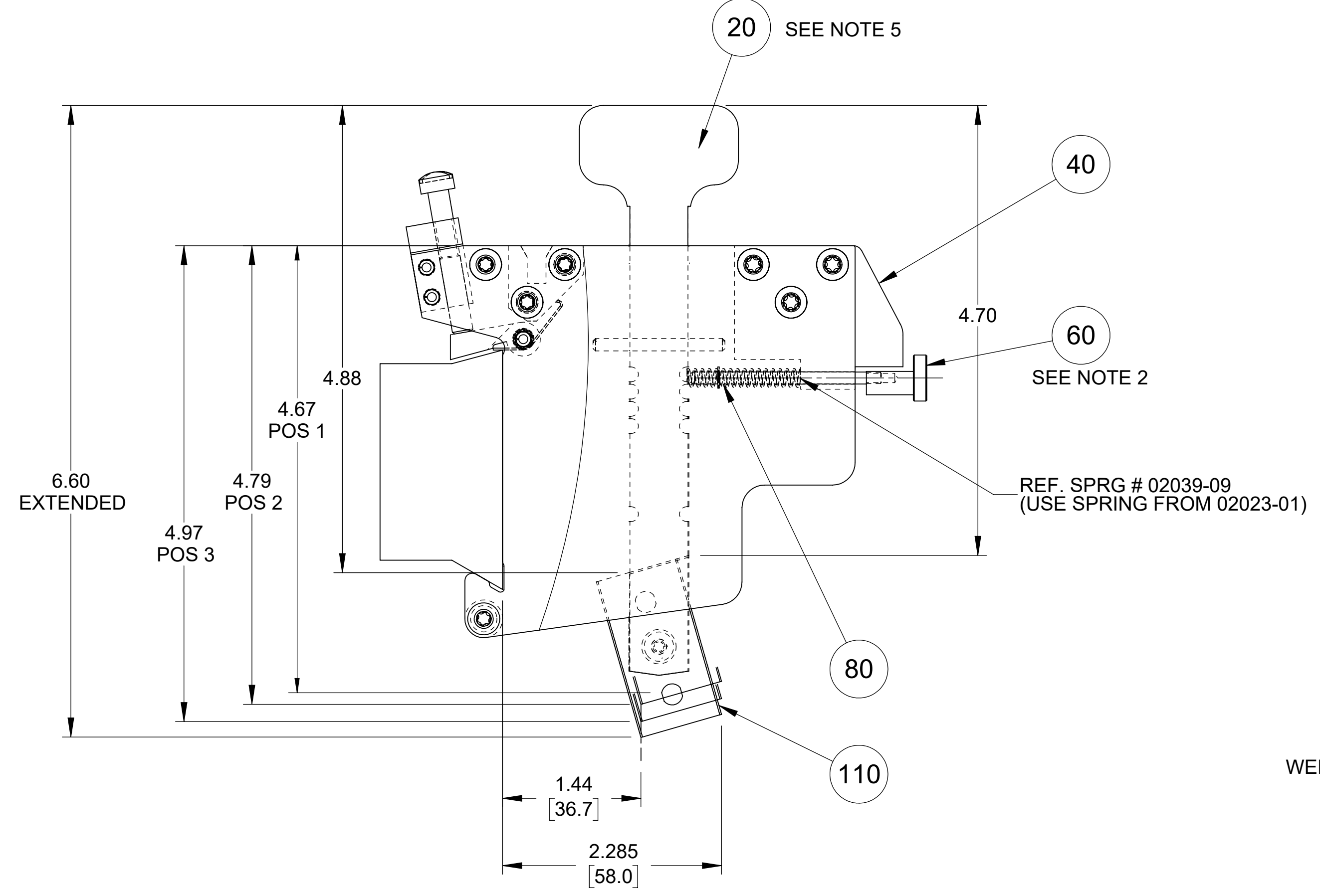
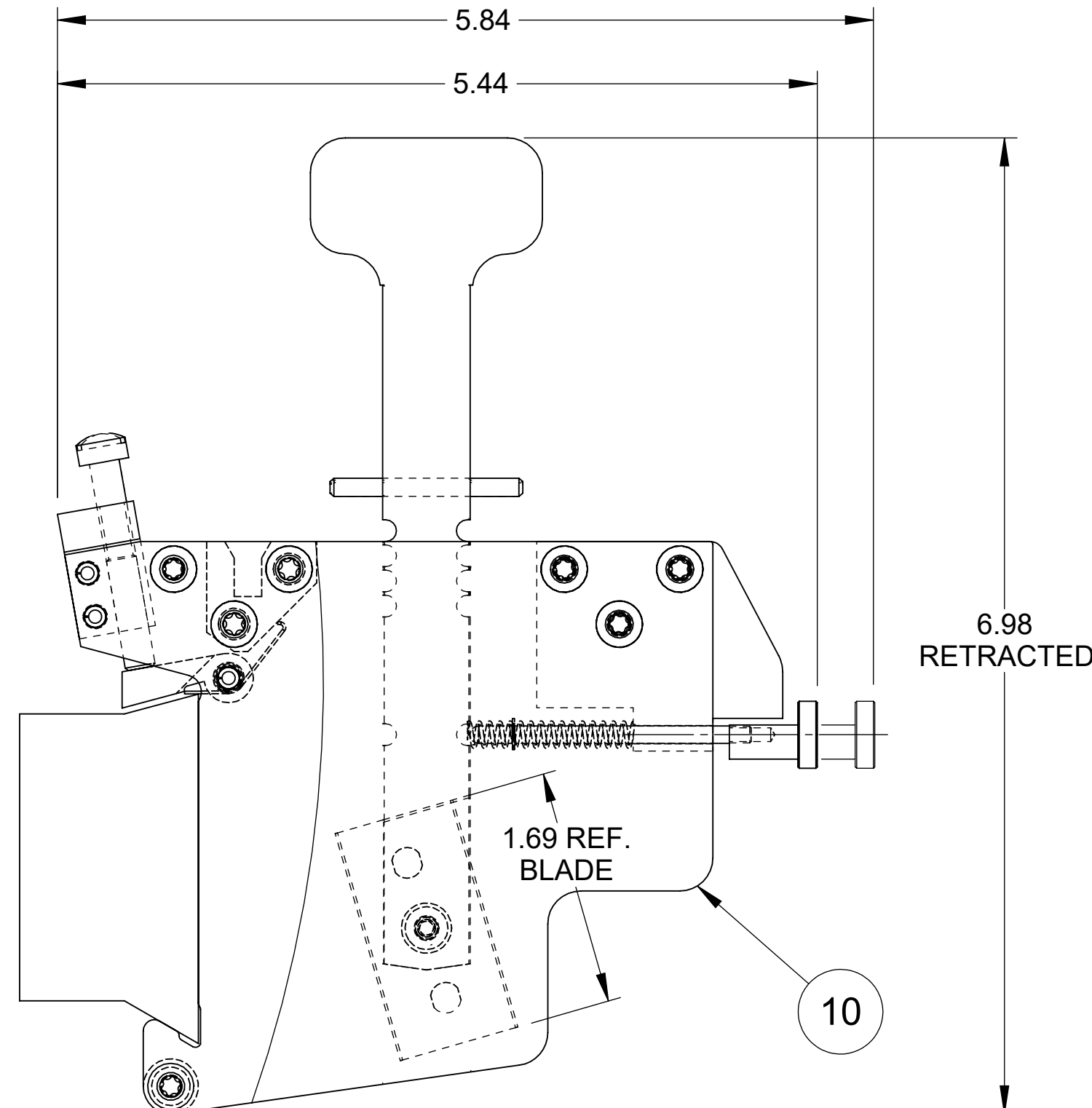
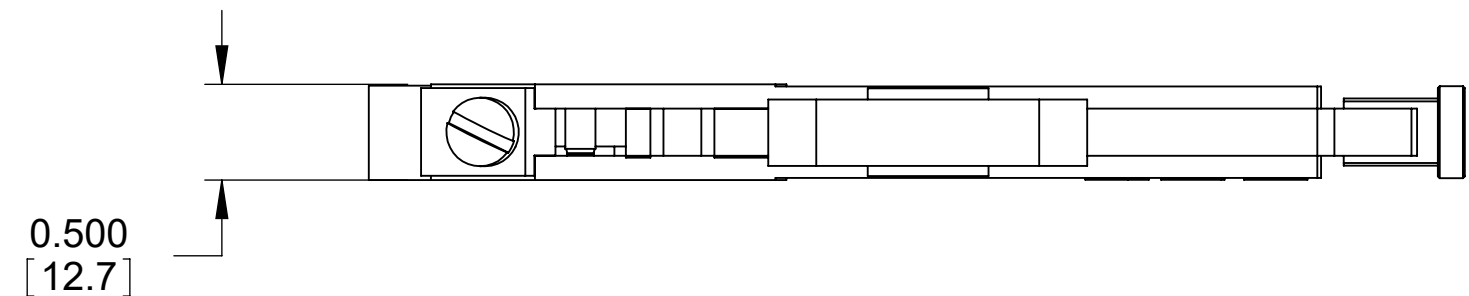
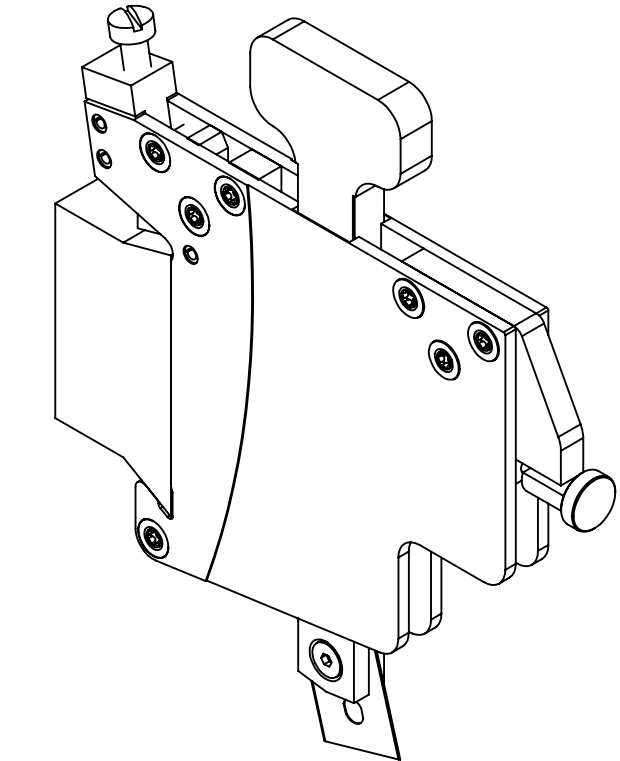
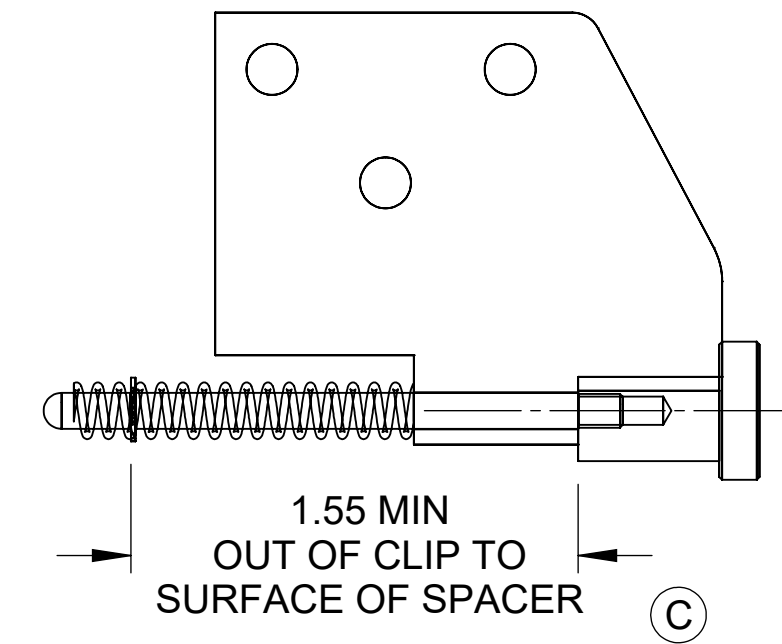

- NOTES:
1. MATERIAL: SEE B.O.M.
 2. USE LOCTITE THREAD RETAINER 262.
 3. APPROX WEIGHT: 2 LBS
 4. PULL AND TWIST TO PROVIDE CLEARANCE FOR RAZOR INSERTION AND REMOVAL.
 5. FOR OPPOSITE WEB DIRECTION, ASSEMBLE (20) IN REVERSED DIRECTION.

6. RETURN THESE ITEMS TO INVENTORY:

02032-09	-1.00	EA	CYLINDER,PRESSURE - PQAS
02033-09	-1.00	EA	GASKET
02034-09	-1.00	EA	KNIFE FORK
02035-09	-1.00	EA	PIN,BRG,1/2" HLDR 22MM BRG
02039-09	-1.00	EA	SPRG,PRESSURE
02041-09	-1.00	EA	HOSE,AIR,TYPE 1 - 20" W/CPLR
02254	-1.00	EA	KNF,CRUSH CUT 3x.866x.244-5210
02599	-1.00	EA	INTERMEDIATE PIECE PQAS 1/2"
02676	-1.00	EA	BRG,BALL,OPEN 8X22X6

This document is the property of Dienes Corporation. It may contain proprietary information. DO NOT USE FOR PURPOSES OTHER THAN THOSE INTENDED.

REFERENCE METRIC DATA	
DIM	TOL
O.D.	
I.D.	
THK.	

DIENES CORPORATION
 Spencer Massachusetts

HLDR,PQAS 1/2" RAZOR MANUAL

Unless Otherwise Noted Dimensions Are In Inches	Drawn by: D. W. BLISS
Tolerances Unless Noted: XXX ±.005 XX ±.010 FRACT. ±.015 ANGLES ±1/2° ±.1°	Date: 6/20/2012
Finish Unless Noted: ✓	Checked by: DB
DO NOT SCALE DRAWING	Date: 8/20/2012
Sheet 1 of 2	Scale: 1:1
Drawing Number: P2190-0001	Rev. C

For Internal DIENES CORPORATION Use Only

PQAS 1/2" Manual Razor Cut Holder
Dienes No. P2190-0001

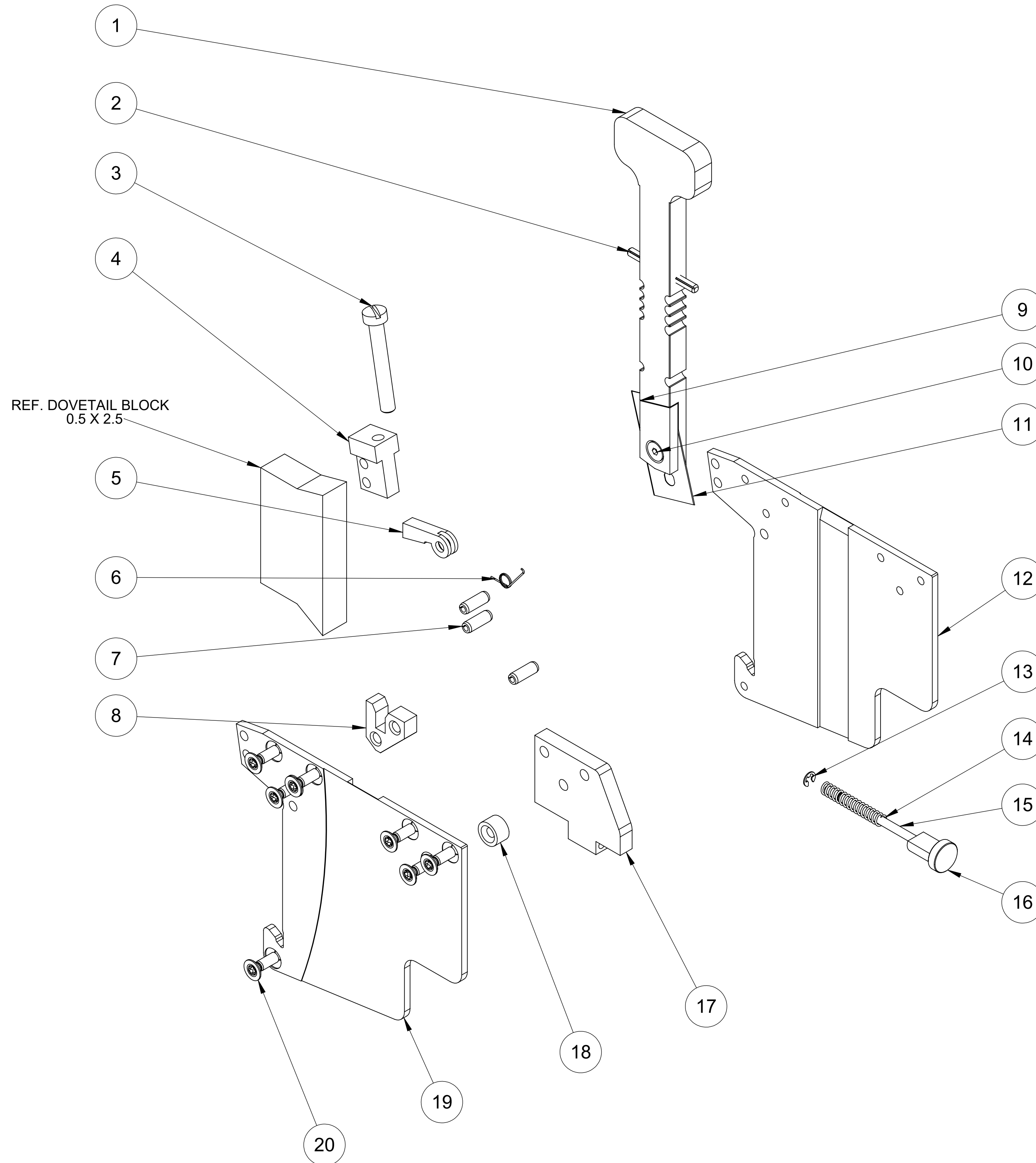

ITEM NO.	PART NUMBER	DESCRIPTION	QTY.
1	416788	SLIDE, RAZOR HOLDER	1
2	655544	PIN ROLL 3MM X 35MM	1
3	02125-09	SCR,FILLISTER HD,12-24X1.5 LG	1
4	02036-09	PQAS Clamp Body	1
5	02037-09	CLAMP ARM PQAS	1
6	412414-01	SPRG,RETURN,PQAS/PQDS	1
7	02777	PIN,SPRING M4x12	3
8	02599	Intermediate Piece	1
9	416789	CLAMP PIECE, RAZOR HOLDER	1
10	614092	SCR,CAP,FL SOC HD,M4X6	1
11	02913	KNF,RAZOR 1.69 X.875 X.008	1
12	02769	PQAS LH Sideplate (Thd holes)	1
13	655062	RING,RETAINING,EXT Ø0.125	1
14	02039-09	SPRG,PRESSURE,30mm LONG	1
15	416792	STUD,LOC PIN,RZR HLDR	1
16	418017	KNOB, LOCATING PIN	1
17	418018	SPACER, RAZOR HOLDER	1
18	02038-09	RING,DISTANCE - PQAS 1/2"	1
19	02768	PQAS RH Sideplate (C'bore'd holes)	1
20	02095-09	SCR,CAP,FL TORX HD,M4x12	7

This document is the property of Dienes Corporation. It may contain proprietary information. DO NOT USE FOR PURPOSES OTHER THAN THOSE INTENDED.

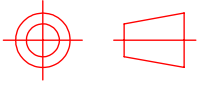
 US PROJECTION		DIENES CORPORATION <i>Spencer Massachusetts</i> HLDR,PQAS 1/2" RAZOR MANUAL	
REFERENCE METRIC DATA		Unless Otherwise Noted Dims in Inches	Drawn by: Admi
DIM	TOL	Tolerances Unless Noted: XXX ±.005 XX ±.005 X ±.010 FRACT. ±.015 English Unless Noted: <input checked="" type="checkbox"/> DO NOT SCALE DRAWING	Date: 2017-06-22
O.D.		Checked by:	Date: 12/08/2020
I.D.		Scale: 1:1	Sheet 2 of 2
THK.		Drawing Number: DP2190-0001	Rev. -
REF DWG:		For Internal DIENES CORPORATION Use Only	